

SHURE®

LEGENDARY
PERFORMANCE™

A Shure Educational Publication

AUDIO SYSTEMS GUIDE

VIDEO PRODUCTION

By Christopher Lyons

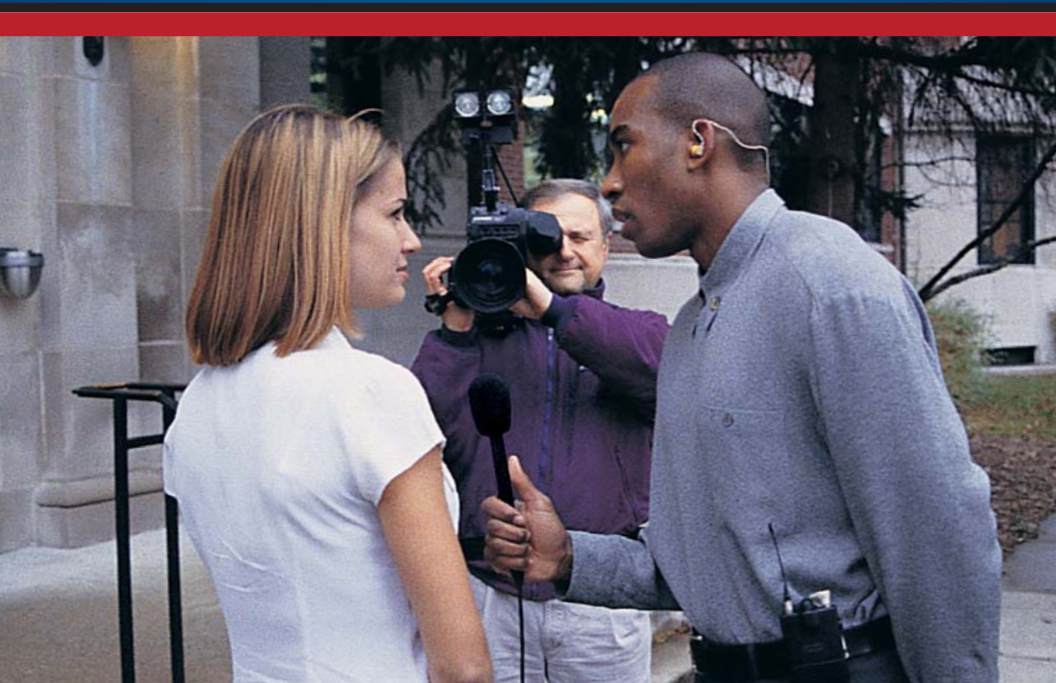



Table of Contents

Introduction	4
The Audio Chain	5
Microphones	5
Cables and Connectors	18
Mixers	20
Connecting to Camcorders	24
How to Handle Some Common Miking Situations	26
Troubleshooting	29
A Few Final Words	32
More Resources	33
Product Selection Charts	34
About the Author	36

Audio Systems Guide for

VIDEO PRODUCTION

Introduction

Because the video production field is enjoying such rapid growth, keeping up with its technological advancements is a real challenge. The equipment used in video production is becoming more sophisticated, practical, and accessible every day, and more and more people are getting involved with video projects of all kinds.

Shure has been deeply involved with the audio side of video production for many years. If there's one thing we've learned over this time, it's that audio quality is a key element that can "make or break" any video project. No matter how creative and well-executed the visual aspects of a production may be, these qualities can be completely negated by lackluster audio. To a greater degree than most people realize, video projects stand or fall on the basis of their audio.

This booklet is intended to help anyone involved with video projects improve the audio quality of their productions. It is not intended as a comprehensive study of the subject of audio. Its real goal is to provide helpful tips, practical advice, and a general knowledge of audio tools – all with the express purpose of making video productions as clear, understandable, and impressive as possible.

Technological advances have helped us make great strides over the years in communicating with one another. As a leader in audio technology, Shure has played a major role in this process. No matter what your involvement with video production may be, we're confident that Shure products will help you achieve the highest possible level of audio excellence in your work. And we hope this booklet will help you use our products with the greatest effectiveness.

Introduction



THE AUDIO CHAIN

Almost everyone has used a simple cassette tape recorder at one time or another. In that instance, the process of recording sound is very simple: press the Record button, talk into the microphone, and press the Stop button when finished. In the world of audio-for-video, however, there may be many pieces of equipment between the microphone and the video-tape recorder. This series of devices is collectively known as the audio chain. Common links in the audio chain include a microphone (which transforms sound into an electrical signal), a mixer (which adjusts the strength of the signal in relation to other signals coming through the same system), and an equalizer, compressor, or other signal processor (all of which merely alter the signal and are optional). When it comes out of the mixer (or whatever extra signal processing devices are required), the signal is ready to be fed into the audio input jack of a video tape recorder or to an amplifier for playback through loudspeakers.

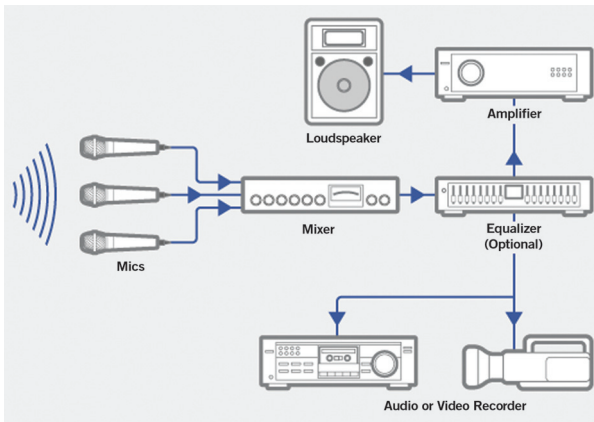

Audio Chain

MICROPHONES

Different types and when to use them

The first step in getting the sound of someone's voice on to your videotape is the microphone. Microphones serve a very basic purpose: to change acoustic energy to electrical energy. They convert sound waves into an electrical signal which can be modified, amplified, or recorded. Since the microphone's function is so basic, you might well ask why there are so many different kinds of microphones. It's simply because some types of microphones are better suited to certain uses than others, just as pickup trucks are better than small sports cars for carrying large, heavy loads. If you are familiar with the different types of microphones, and how and when to use them, your productions will start sounding less like a home video and more like the nightly news.

Audio Systems Guide for VIDEO PRODUCTION

Physical Design

In choosing a microphone for a specific application, the first thing that must be considered is how it will be used. Will it be held by the person talking? Will it be clipped to the user's clothing? Will it be located a few feet away from the subject, so that it remains out of the frame?



Examples of different microphone designs

Handheld — The most common kind of microphone is the handheld type. This style is the most flexible, because it can be held by the user, mounted on a floor or desk stand, or attached to a flexible “gooseneck” on a lectern. A good quality handheld mic should have an internal shock mount which will minimize handling noise (thumping sounds transmitted through the handle and picked up by the microphone cartridge), and it should be ruggedly constructed to withstand physical abuse. If you can have only one microphone in your kit of audio gear, it should be a handheld mic. Models at the upper end of the price scale will usually offer clearer, wider-range sound, better shock mounting, and more durable construction.

Tips on Using Handheld Mics: Whether held in the hand or mounted on a stand, the microphone should be positioned about 6”-12” from the talker’s mouth, pointing up at about a 45-degree angle. With some types of microphones, holding the microphone very close (3”-6”) will cause additional emphasis of the lower frequencies (known as proximity effect), resulting in a “warmer”, bass-heavy sound.

Lavalier — Another popular mic for video use is the lavalier type. Historically, the word “lavalier” refers to microphones which are hung on a cord around the wearer’s neck, but the term has grown to include almost any small microphone that attaches to the user’s clothing. Lavalier microphones leave the talker’s hands free to gesture, hold notes, or demonstrate a product. In addition, they are usually very small and therefore tend to disappear on camera. Also, using a lavalier will keep the distance from the microphone to the talker’s mouth fairly constant, reducing the need for frequent mixer adjustment once the levels have been set.

A disadvantage of lavalier mics is the fact that they tend to be single-purpose microphones — they rarely sound good if handheld or used away from the body. While the lavalier mic’s small size makes it easy to conceal behind lamps or other objects, an equalizer is usually necessary to make the mic sound natural when it is not attached to the person talking.



Illustration: Ideally, a handheld microphone should be positioned six to twelve inches from the user’s mouth, at an angle of 45 degrees or less. This usually avoids air currents that result in “popping” sounds when the consonants “P” or “T” are pronounced.

Tips on Using Lavalier Mics: For best results, lavalier mics should be placed on the outside of clothing, about six to eight inches below the chin. They are generally clipped to a pocket, lapel, or necktie. If none of these options are available, the mic can also be clipped to the collar of a shirt or blouse. Sound quality in this position tends to be somewhat muffled, however, because some high frequencies (which contain consonants) do not fully wrap around to the area under the chin.

Concealing a lavalier microphone — In some productions, it is necessary to conceal the microphone. It is important to prevent both the microphone and the first few inches of cable from rubbing against either the body or clothing, which will cause noise. Here are some options:

- Under the shirt collar. The mic is lightly taped to the inside of a dress shirt collar, near the opening in front. The cable can be routed around to the back of the neck, over the collar and under the shirt.
- On eyeglasses, on the inside of the temple. The cable is routed over the ear and down the back.
- On the forehead or cheek, secured with medical tape or gum. A disadvantage of this method is that the microphone is directly exposed to perspiration and makeup.
- On the chest, secured with double-sided tape to both the skin and the inside of the shirt. Try to avoid placing the mic behind any material having more than one layer. This reduces pickup of high frequencies, which results in a flat, “muddy” sound.

Audio Systems Guide for VIDEO PRODUCTION

Double-miking — In some cases, even a remote chance that the microphone might fail during a live event constitutes an intolerable risk. For this reason, a news anchor or key presenter may wear two lavalier microphones for redundancy. Only one mic is used at a time; if the primary mic fails, the backup mic channel can be turned up immediately.

Double-miking with lavalier microphones is usually achieved with a special tie clip or bar that holds two microphones. (Note: When wireless microphones are used, each lavalier mic must be connected to its own body-pack transmitter. These two transmitters must be on different operating frequencies, and their signals must be picked up by two different receivers, as discussed later.)



A lavalier microphone should be positioned six to eight inches below the wearer's chin (Shure WL93 shown).

Surface Mount — These microphones are designed to work on a flat surface. They are usually physically contoured to look less intrusive on a conference table or desktop. The microphone element is located very close to (but not touching) the surface, so that sound waves reflected from the surface arrive at the mic element at the same time as the direct sound. This effectively doubles the sensitivity of the microphone compared to a free-standing handheld type at the same distance. (This sensitivity boost assumes that the surface is sufficiently large to reflect even low-frequency sound waves.)

Tips on Using Surface Mount Mics: Surface mount microphones work best when positioned on a smooth, flat surface, such as a table or desk. If table vibrations are a problem, try putting a very thin piece of soft foam rubber underneath the mic. (A computer mouse pad with a hard top surface often works well.) In some situations, surface mount mics can even work well when mounted on a wall. Keep in mind that the sound quality of this type of microphone is affected by the size of the surface on which it is placed. For best results, use a surface at least 3 feet square; using a smaller surface will tend to reduce pickup of low frequencies. The effect on speech frequencies is usually mild, and may actually improve intelligibility of very low voices by reducing boominess.

Shotgun — The shotgun microphone is so named because the long, slotted tube in front of the microphone cartridge makes it resemble a shotgun. This “interference tube” helps reject sounds coming from more than about 30 degrees off to the sides, while still picking up sounds from the front. This extremely directional pickup pattern (called a line/gradient pattern) makes shotgun mics popular for TV news and movie sets.

Shotgun microphones are not telephoto lenses for sound. They do not allow you to zoom in on a conversation from 100 feet away. Here's a much more accurate analogy: imagine looking through a long tube at a person standing 20 feet away. The person's image does not appear to be any larger or closer, but is somewhat easier to see, because the eye is not distracted by things happening off to either side. This is exactly what shotgun mics do best - screen out sounds coming from the sides. In practice, a shotgun microphone can typically be placed at four to five times the acceptable distance for a standard omnidirectional microphone. Keep in mind that the shotgun mic will also pick up sounds coming from behind the subject.

Tips on Using Shotgun Mics: Shotgun mics can be positioned either slightly above, below, or to the side of the sound source, so that the mic does not appear in the camera frame. Try to avoid aiming the mic at a hard surface, such as a tile floor, brick wall, or hard ceiling. These surfaces reflect sound waves, and may reflect background noise into the microphone or cause the sound to be slightly hollow. A heavy blanket can be placed on a reflective surface to provide some temporary sound absorption. Shotgun mics are more sensitive to wind noise than standard microphones, so try to avoid moving the mic rapidly and use a foam windscreen if possible. Larger “zeppelin” or “blimp” type windscreens are usually necessary outdoors. Also, it's a good idea to use a rubber-isolated shock mount to control handling noise that may be transmitted through a stand or boom.

Directionality

Directionality is one of the most frequently misunderstood characteristics of a microphone. Simply put, directionality describes how a microphone responds to sounds arriving from different directions or angles. Some microphones pick up sounds equally well from all angles, while others favor sounds from a particular direction. Understanding the significance of a microphone's directionality is vital to getting the most from its capabilities in any given miking situation.

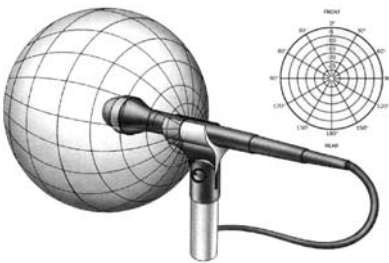

Omnidirectional Microphone

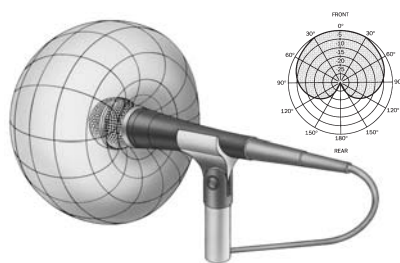

Cardioid (Unidirectional) Microphone

Audio Systems Guide for VIDEO PRODUCTION

The most common way of illustrating a microphone's directionality is with a polar pattern. This is a circular graph which illustrates the relative sound pickup from different directions. Although many different polar patterns are possible, the most common ones fall into two general categories: omnidirectional and unidirectional.

Omnidirectional — An omnidirectional microphone picks up sound equally from all directions (the prefix “omni” means “all”). An omni mic will pick up sound from above, below, in front of, behind, and to the side of the mic in a 360 degree sphere. The polar pattern for an omni, then, is roughly circular. This can be advantageous, since one omnidirectional microphone can be used to pick up voices from several directions, as long as each person talking is approximately the same loudness and the same distance from the microphone. The handheld microphones used by news reporters are usually omnidirectional, allowing the reporter and interviewee to be picked up by one microphone held between them. It is important to note that omnidirectional microphones do not suffer from the bass boost proximity effect mentioned earlier.

There are some drawbacks to consider when using omnidirectional mics, however. First, since they pick up sounds equally well from all directions, they may pick up undesired background noises (doors slamming, traffic, etc.) as well as the desired source. Second, they tend to pick up greater amounts of room reverberation when used in rooms that have hard-surfaced walls and floors. This can sometimes result in a diffuse, hollow, “inside a barrel” sound. This effect may be minimized by moving the microphone closer to the source and turning down the input level control at the mixer to compensate. A third drawback to omnidirectional mics is that, when fed through a loudspeaker system for sound reinforcement, they tend to produce feedback easily. (We'll discuss feedback and room reverberation in more detail in the Troubleshooting section.)

Unidirectional — A unidirectional microphone rejects sound coming from behind the mic while still picking up sound from the front. For this reason, unidirectional microphones pick up less room reverberation and are less susceptible to feedback when used with loudspeaker systems. There are different kinds of mics that fall into this category, each one having a slightly different polar pattern and its own set of advantages and disadvantages.

By far the most common type of unidirectional microphone is the cardioid, so named because its polar pattern resembles a heart-shaped figure. Most cardioid mics will pick up less than half as much sound from the sides as from the front, and less than one tenth as much sound from the rear as from the front. So, the cardioid mic tends to pick up more of the desired sound and less of the undesired sound.

Other unidirectional types such as the supercardioid and hypercardioid have progressively greater rejection of sounds from the sides, but pick up more sound from the rear. Using these more directional patterns requires that the talker be more careful about staying directly “on mike” and not straying off to the sides, where the mic's sensitivity drops off rapidly.

Most types of microphones are available in both omnidirectional and unidirectional versions. Lavalier microphones are usually omnidirectional, although unidirectional models are becoming popular. The shotgun microphone is by definition extremely directional.

Transducer Type

As mentioned earlier, microphones serve just one purpose: to convert sound waves into electrical energy. The part of the mic that actually does the conversion is called the transducer or cartridge. But different types of transducers perform the conversion in different ways, and each type of transducer has certain characteristics that make it more or less suitable for various applications. For the most part, two types of transducers are used in microphones for broadcast and audio-visual productions: the dynamic and the condenser.

Dynamic microphones (also called moving coil microphones) use a simple magnet and coil of wire to convert sound waves into an electrical signal. Here's how it works: a thin diaphragm with a coil of fine wire attached vibrates in response to sound waves. This causes the coil of wire to move back and forth around a magnet, creating a small amount of electricity, which flows through the microphone cable.

Good quality dynamic mics offer very good sound quality, are very rugged, and will usually tolerate rough handling or exposure to extreme temperatures and humidity. For these reasons, dynamic microphones have traditionally been the most popular for most professional applications.

Condenser microphones (also called capacitor or electret condenser microphones) use an ultra-thin piece of plastic or metal stretched tight just above a piece of flat metal or metal-coated ceramic, called a backplate. When a fixed electrical charge is placed on the diaphragm/backplate assembly, its electrical output varies depending on the movements of the diaphragm, which vibrates in response to sound waves. This output signal is extremely weak and subject to outside electrical interference, however, so it must be modified and/or

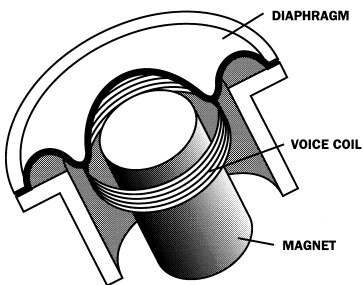

Dynamic Microphone

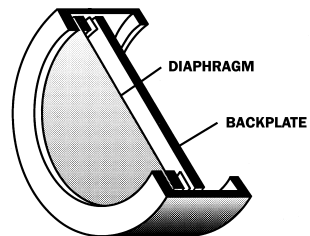

Condenser Microphone

Audio Systems Guide for VIDEO PRODUCTION

amplified by a circuit called a preamplifier. The preamplifier can either be located in the handle of the microphone or in a small onboard electronic pack.

Condenser microphones offer several benefits. The most important of these is that they can be made very small, which is why all miniature lavalier microphones are condenser types. Condensers tend to be very sensitive to the extreme low and high frequencies, and usually have a very crisp, clean sound. Their built-in preamplifiers allow condenser mics to provide higher output than dynamic mics, meaning that for a given sound level, a stronger electrical signal comes out. This may be helpful when you are trying to pick up someone who speaks very softly, or who is further away.

You'll encounter one inconvenience in using condenser mics, however, in that the preamplifier requires electricity to work. On some microphones, this can come from a battery carried inside the handle of the mic or in the preamplifier pack. Power can also be supplied from the mixer or other equipment that the mic is plugged into, if it is so equipped. This is called phantom power, and will be discussed later.

Electrical Impedance

Impedance is an electrical characteristic of audio equipment, just like voltage or current. It is expressed in ohms, the symbol for which is Ω . Microphones are typically classified as being low-impedance (also called low-Z) or high-impedance (also called high-Z). For professional applications, only low-impedance microphones should be used. High-impedance microphones usually begin to sound muffled due to a loss of high frequencies when used with a cable longer than 20 feet. One of the advantages of low-impedance microphones is that they allow you to use very long runs of cable (over 1000 feet) with negligible loss of sound quality.

It's usually not difficult to tell if the microphone you're using is high-impedance or low-impedance; just look at the nameplate or specification sheet. The words "high-Z", "high impedance", or a rating of 10,000 ohms or higher all indicate a high-impedance microphone. "Low-Z", "low impedance", or a rating of 600 ohms or less indicate that the mic is low-impedance. High-impedance microphones can only be connected to high-impedance audio inputs. Use of a matching transformer (which will be discussed later) can facilitate connection of high-impedance mics to low-impedance inputs, or low-impedance mics to high-impedance equipment.

It is important to note that the impedance of a microphone should not match the impedance of the input to which it is connected. In fact, matching the impedance causes a significant loss of signal level. The tradition of matching impedances originates in the early days of electronics, when amplifiers were based on vacuum tubes. With modern transistorized electronics, low impedance devices (such as microphones) should always be connected to an input whose impedance is higher — preferably 5 to 10 times higher. For this reason, the inputs on professional mixers typically have an impedance of 1000 ohms or higher.

Phantom Power

A little earlier, we talked about the fact that condenser microphones require electrical power to operate (usually between 11 and 48 volts DC). Phantom powering is a method of supplying that power through the microphone cable from a remote supply. This supply can be a stand-alone unit or may be incorporated in the audio mixer, or, in some cases, the video recorder. It is called "phantom" power because it comes from somewhere outside the microphone and is not supplied by a battery.

While it's a popular myth, plugging a dynamic microphone (which doesn't need any power to work) into a mixer that is supplying phantom power will not damage the microphone. As long as you are using a balanced microphone, phantom power cannot possibly cause it to burn out, or harm it in any way. If you connect an unbalanced microphone to an input that is supplying phantom power, you may hear a steady hum or buzz. To get rid of it, just turn off the phantom power supply. (We'll discuss the concept of "balanced" and "unbalanced" in the Cables and Connectors section.)

Phantom power is occasionally referred to as simplex power; the two are one and the same electrically. You may also encounter some European microphones which require a different type of power called A-B power or T power. These are electrically incompatible with phantom power. Microphones which operate on phantom power will not operate on A-B power, and vice-versa. Some mixers can provide phantom power and A-B power to different mic inputs simultaneously.

What About Wireless?

Wireless microphones (occasionally referred to as "RF mics" or "radio mics") have become increasingly popular in the last few years, especially in situations where the presence of a conventional mic cable puts constraints on the user's actions. In essence, a wireless microphone is a miniature radio station. A microphone cartridge (which may be a dynamic or condenser type) converts incoming sound waves to an electrical signal. The signal is sent out by a low-power transmitter, and then picked up by a receiver located nearby, which converts the radio-frequency signal back into audio. The transmitter can be contained in the handle of the microphone or in a small pack designed to be worn on the body. The combination of the microphone, transmitter, and receiver is known as a wireless system. A cable then connects the audio output of the receiver to the input of the audio mixer or videotape recorder.

Just like radio stations, wireless microphones operate on specific frequencies in sections of the frequency band which are regulated by the Federal Communications Commission (FCC). These frequencies are measured in megahertz (abbreviated "MHz"), which describes the number of times that the signal oscillates or vibrates in one second. Wireless microphone systems are available in different sections of the frequency band:

The **low-band VHF** (49-72 MHz) range is utilized by radio-controlled toys, cordless telephones, baby room monitors, and other consumer products. Wireless microphone

Audio Systems Guide for VIDEO PRODUCTION

systems on these frequencies — particularly 49 MHz — are likely to pick up interference from some of those items. While low-band VHF systems are typically very inexpensive, their performance is generally acceptable only for home video recording use.

The **high-band VHF** (169-216 MHz) range is used for professional applications, and quality systems are available at a variety of prices. This region is the same one in which VHF television stations (channels 7-13) broadcast, so it is important to be aware of which stations are in the geographic area where the wireless system is to be used. In Chicago, for instance, there are TV stations on channels 7, 9, and 11, so wireless systems operating in channels 8, 10, 12, or 13 may be used. Manufacturers of wireless systems can help you select the optimal frequencies for use in your area, considering other units already in use at your location and the number of systems to be used.

If you intend to use your VHF wireless microphone system in various parts of the country, you might choose one of the so-called “traveling” frequencies. These are frequencies in the 169-172 MHz range which are just below channel 7, and therefore not subject to interference from TV stations. Traveling frequencies are by far the most crowded, however, and in some areas they are used by navigation buoys or hydroelectric equipment to broadcast control signals which may interfere with your wireless mic. Keep this in mind when using wireless microphones near coastal areas or dams.

The UHF frequency range has become the most popular as congestion in the VHF band has increased. Since the UHF band is generally less crowded than VHF, there is less chance of encountering interference from another user on the same frequency. There is no

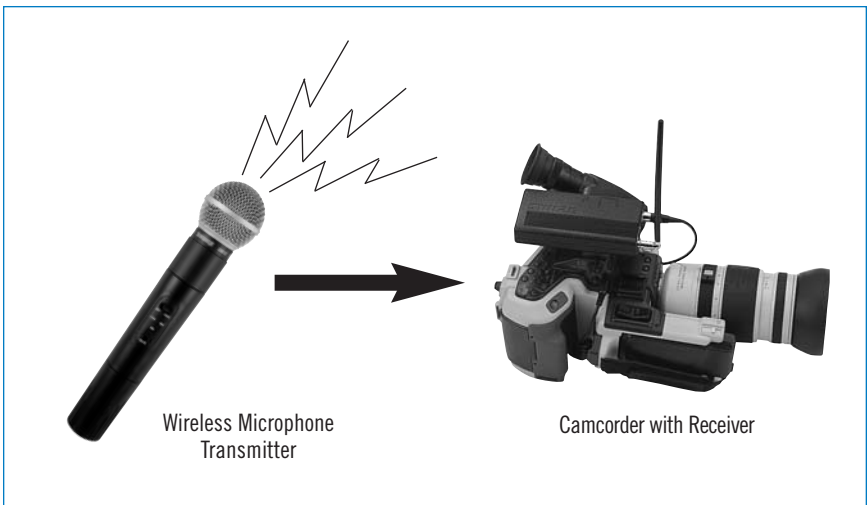

Audio chain incorporating a wireless microphone system

inherent difference in sound quality between UHF and VHF wireless microphones. Due to their more complex design and circuitry, however, UHF systems are typically more expensive than comparable VHF systems. It should be noted that UHF and high-band VHF frequencies are reserved by the FCC for use in broadcast and film/video production, but it is the responsibility of the purchaser to observe FCC rules regarding their use. Regulations regarding authorized use of these frequencies have not been strongly enforced in the past, however, with the result that it is not unusual to find professional frequencies being used by unauthorized users.

Once you've narrowed down the list of possible frequencies to use, you need to decide which of the two types of receivers you need: single antenna or diversity. The first type utilizes a single antenna mounted on the back of the receiver. The RF signal from the transmitter's antenna radiates in all directions, and gets reflected off large surfaces like walls and ceilings. The reflected signal can add to or subtract from the direct signal, sometimes resulting in a net signal strength of zero at the receiving antenna's position. This condition, known as multipath interference, may come and go rapidly as the person carrying the transmitter moves around the room, causing the RF signal to be interrupted for a fraction of a second. This is called a dropout. Depending on the duration and severity of the dropout, you may hear a quick "pfft" sound, a brief buzz or crackle, or a complete loss of audio.

Diversity receivers do a better job of resisting signal interruptions. They utilize two antennas — mounted a short distance from each other — and a "smart" circuit that selects the better of the two signals at any given moment. Diversity receivers provide a noticeable improvement in audio quality, since it is unlikely that the signal to both antennas will be interrupted at the same instant.

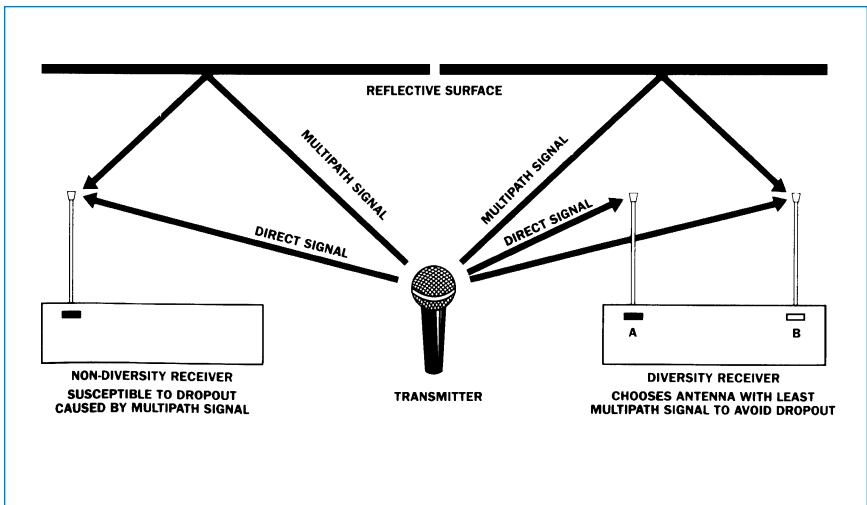

Non-diversity and diversity explanation

Audio Systems Guide for VIDEO PRODUCTION

Portable battery-powered wireless receivers are available for use in situations where both the transmitter and the receiver must move around. These units are very small — usually about the size of a cigarette pack — and can be worn on the body or mounted directly to a small mixer or camcorder. A short cable connects the audio output of the portable receiver to the audio input of the mixer or camcorder. Better models offer a separate headphone output, so that the camera operator can monitor the audio through headphones or an ear piece. A wireless microphone system which includes a portable receiver is a very handy thing to have on a video shoot. For instance, one or more receivers can be attached to the top of a portable audio mixer, which then feeds audio to the camcorder through a short cable. This way, the talent, the camera operator, and the sound engineer can all move about freely when the script requires such a shot.

Another application for a portable wireless receiver is to feed audio from the mixer to a camcorder located across the room. In a large meeting room, for example, the audio mixer is often located at one side of the stage, while the camcorder is at the back of the room. In such a scenario, an output from the mixer can be connected to the input of the wireless transmitter, and the portable receiver attached to the camcorder. This eliminates the need to rely on the camcorder's internal microphone, which is usually too distant from the talkers to provide satisfactory sound quality.

A new spin on the portable receiver concept is the wireless in-ear monitor system. This is a wireless system specifically designed to feed audio to the talent's ears, rather than to a mixer or camcorder. The desired signal is connected to a stationary transmitter, which broadcasts the signal to any number of body-pack receivers worn by talent or crew members. The receiver feeds small earpieces that are nearly invisible on camera.



Example of a wireless diversity system (Shure ULX Wireless shown).

The receiver must be equipped with a headphone volume control so that the listener may adjust the volume to a level that is comfortable and safe. Better systems offer the option of transmitting either stereo audio or two simultaneous mono channels, which the listener can blend and adjust to their preference.

Wireless in-ear or “personal” monitors can be used in a variety of ways in the broadcast or video production environment. Reporters in the field can hear questions and answers from the broadcast studio; the narrator of a video program can listen to a prerecorded script while simultaneously reciting it (sometimes called an “ear prompter”); an actor can hear stereo music playback while singing along; a presenter can hear questions picked up by audience microphones. In many applications, the director can cut in to give instructions; the monitor signal is then called Interruptible Foldback, or IFB.

Tips on Using Wireless Systems: When using wireless microphone systems, try to keep the distance from transmitter to receiver as short as possible. Always do a “walkaround” before the event begins; that is, listen to the system while walking around the anticipated performance area. If dropouts occur, try moving the receiver a few feet and repeat the walkaround. If possible, the walkaround should be done at the same time of day as the event, to expose nearby users of the frequencies on which you intend to operate. When using belt-pack type transmitters, be sure that the antenna cable is hanging straight. If it is coiled up in the wearer’s pocket, transmission distance will be significantly reduced. With handheld transmitters that have an external antenna, discourage users from holding their hand over the antenna, which will reduce transmission range and increase the likelihood of dropouts.



Example of a Personal Stereo Monitoring (PSM) System (Shure PSM 700 Wireless shown).

CABLES AND CONNECTORS

Cables and connectors are probably the most overlooked link in the audio chain, and yet poor quality cables and/or faulty connectors are frequently the cause of major audio problems.

There are basically two kinds of connections used between audio devices: balanced and unbalanced. A balanced connection requires a cable with two wires (one for the “hot” signal and one for the “return”) enclosed by a shield of metal foil, braid, or mesh. The shield intercepts the random electrical signals that bombard the cable from various sources and drains them to ground. Together, the wires and the shield keep the audio signal free of interference. For applications in which cables will be frequently disconnected and coiled up for storage, choose those which use braid or mesh shielding; these are more resistant than metal foil to cracks or tears due to flexing, which can cause electrical shorts.

An unbalanced connection utilizes a cable with a single wire surrounded by a shield, but in this case the shield has to do double-duty. It carries the “return” portion of the audio signal as well as protecting the wire inside from electrical interference. This method is not nearly as effective as the balanced type, so unbalanced audio cables are easily affected by florescent light fixtures, some types of dimmer switches, and other audio or electrical cables that may be nearby.

Balanced audio connections are generally used with low-impedance equipment, while unbalanced connections are used with high-impedance equipment. You may encounter exceptions, however. As a rule, balanced connections will offer much cleaner, noise-free performance.

You may be wondering, “How will I know if a connection is balanced or unbalanced without cutting the cable open to look?” Fortunately, you can make a pretty accurate guess by looking at the connectors on each end of the cable. As you’ve probably found out, there are several different kinds of connectors found on audio equipment, and some are better than others.

Today, the most popular connector for professional microphones and audio equipment is the XLR connector. Male XLR connectors have three pins, and are used for signal output; female XLR connectors have three sockets, and are used for signal input. The XLR connector is very rugged, rarely bends or breaks off while connected, and most versions lock together securely so that accidental unplugging is unlikely. A cable that has an XLR connector at both ends almost certainly indicates a balanced connection. XLR connectors are found on both low- and high-impedance microphones.

Another popular audio connector is the male 1/4 inch phone plug, which mates with the female 1/4 inch phone jack. The name originates from use of this connector on early telephone switchboards. These can be found on cables used with almost any type of audio equipment: headphones, loudspeakers, amplifiers, signal processing gear, and microphones. Two-conductor types (sometimes called “TS” or “tip-sleeve”, which refers to the area of the connector used for each wire) have two distinct segments and are used for unbalanced mono connections. Three-conductor types (sometimes called “TRS” or “tip-ring-sleeve”)

can be configured to carry a balanced mono signal or an unbalanced stereo signal. Microphones and microphone inputs on mixers using 1/4 inch phone connectors are almost always of the unbalanced high-impedance type.

Another type of audio connector is the miniplug. Miniplugs come in two sizes. The 3.5 millimeter version is the same size as those used on Walkman-type headphones; the 2.5 millimeter size is frequently used for the earphones supplied with transistor radios. The miniplug resembles a miniaturized version of the 1/4 inch type, and is notorious for bending or breaking if bumped while plugged in. Due to their small size, however, miniplug connectors are frequently used on consumer and even semi-professional video equipment. They almost always indicate an unbalanced audio connection, but whether the input is low-Z, high-Z or somewhere in between is usually anybody's guess. Most microphones that come equipped with miniplugs are low-cost units designed for inexpensive tape recorders. If your equipment only has a miniplug or 1/4" microphone input, you can still use a good quality professional mic. You just need to obtain a cable with the appropriate connectors, or in some cases, an impedance transformer (more about equipment interconnection later).

The fourth type of connector you'll run into is the male RCA plug or phono plug, which mates with the female phono jack. The name "phono" comes from the fact that these are the standard for connecting phonograph turntables (as well as tape decks, CD players, and so on) to home stereo equipment. Phono plugs are really not designed to be inserted and removed over and over again, as doing so will eventually result in a broken or intermittent electrical connection. At that point, the usual procedure is to throw the cable away and buy a new one; the problem is that you never know when it's going to happen.

If you are upgrading your audio equipment and are thinking about buying better microphones, it goes without saying that you should invest in some heavy-duty microphone cables with XLR connectors. If your equipment uses 1/4", miniplug, or RCA connectors, buy professional quality cables with metal connectors that can be disassembled for service rather than molded-on plastic connectors. If you do have a problem with a connection, you can repair it rather than replace the entire cable. It is a good idea to carry one spare cable of each type that you use, so that you can change a suspect cable quickly when a problem arises.



Connectors commonly used for audio (left to right): XLR (male), XLR (female),
1/4-inch phone plug, RCA or phono plug, 3.5 mm mini plug.

MIXERS

Unless your application requires just one microphone or your audio or videotape recorder has a number of microphone inputs, you will need to use a microphone mixer. The mixer allows you to take signals of different levels from several sources and combine them into one signal which can then be fed into an amplifier, videotape recorder, or other audio equipment. Some mixers have a variety of input connectors, designed to accommodate signals of different types and levels. A popular audio mixer is shown in the accompanying photo.

Mic And Line – What Do They Mean?

Some mixers have switches on the rear panel for setting each input or output jack for mic level or line level. These refer to the signal level or intensity that the input is designed to accept.

A mic-level or microphone-level signal is the amount of voltage that comes out of a microphone when someone speaks into it — just a few ten-thousandths of a volt. (Of course, this voltage varies somewhat in response to changes in speaking volume and source-to-mic distance.) A line-level signal is approximately one volt, or about 10,000 times as strong as a mic-level signal, so the two do not ordinarily use the same input. Connecting a microphone to a line-level input will result in almost no sound at all, because the signal is so faint that the line input cannot hear it. Connecting a line-level source (such as a CD player) to a mic-level input will cause the sound to be loud and distorted because the line signal is much stronger than what the mic input will accept. Inputs and outputs on better mixers are switchable for either mic or line level operation.

You may also encounter jacks marked “aux” (or “tape”) and “phono”. Aux-level inputs and outputs are found on many kinds of equipment, including VCR’s, tape recorders, CD players, and some computer sound cards. Aux-level is somewhat close to line-level, but aux-level inputs and outputs are nearly always unbalanced, using RCA or 1/4” connectors. Microphones cannot be connected directly to aux inputs. Jacks marked phono are for phonograph turntables only, and are not compatible with anything else.



Example of a microphone mixer (Shure FP33 shown).

Mixer Features

On the front panel of the mixer (shown on page 20) are low-cut filter switches for each input. Such switches are often labeled “In” and “Out” rather than “On” and “Off”, a custom resulting from the fact that some additional circuitry is being placed “in” the signal path. Moving these switches to the “In” or “On” position filters out some of the low frequencies from the signals on those channels. This feature comes in handy for reducing the rumbling noises which often come from air conditioning, wind noise, etc. The limiter feature is extremely useful, and it will not hurt to leave it on all the time. A limiter acts as a ceiling for the audio signal, and tries to keep it below the point at which distortion occurs. Some limiters can be adjusted to activate at different levels, called the threshold. The switch marked “1kHz” controls the built-in tone oscillator, sometimes called a tone generator. This tone, usually at a frequency of 1,000 Hertz, is used for adjusting several connected pieces of equipment (see section on setting levels for more details.)

Automatic Mixers

Problems often arise when multiple microphones are used for recording or sound reinforcement. As more microphones are added, pickup of reverberation and unwanted room noise increases, which decreases intelligibility. In situations where a sound reinforcement system is being used, additional microphones also increase the likelihood of feedback or “howling”. These problems cause listener fatigue, as it becomes necessary to concentrate harder to comprehend the talker’s message. The solution is to activate microphones only when they are being addressed and to keep them turned down when they are not needed. In addition, when more than one microphone is addressed at a time, the overall sound system volume must be reduced slightly to prevent feedback.

Automatic or voice-activated mixers are designed to do both of these things, without the aid of a live operator. Automatic mixers have special circuitry added which senses when sound is arriving at a microphone, and then turns on that microphone. The best units are able to turn on or “gate” the microphone in just a few thousandths of a second - so fast that not even the first syllable is missed. Some automatic mixers use ordinary microphones, while other types require special microphones. The latter type can actually sense the location of the sound source and activate the microphone only when the sound comes from the desired direction. This prevents background noises, such as doors opening, from fooling the mixer, no matter how loud they are.

Audio Systems Guide for VIDEO PRODUCTION

Setting And Adjusting Levels

To achieve professional sounding results, it is important that the mixer you use is equipped with a meter. Without one, it is nearly impossible to adjust signal levels properly. The most popular type is called a VU meter (VU stands for “volume units”), and may be in the form of either a needle-type indicator or a series of light-emitting diodes (LED’s).

During setup, first set the master gain control knob to about 3 or 4. Then have each speaker talk into his or her microphone in a normal voice. Don’t let them lean close to the microphone and quietly say “hello” — have them state their name and enough other miscellaneous information (hometown, etc.) to give you enough time to set an accurate level. Watch the meter carefully, and adjust the input channel knob (also called a “fader” or “pot”) so that the needle hovers below 0 VU, and only occasionally goes into the red zone. If the meter is ever “pegged” (with the needle hitting the far end of the scale), it means you’ve set that input level too high. Repeat this procedure for each input channel. If you will be turning down mics that are not being addressed, write down the appropriate setting for each channel on a piece of tape and stick it on top of or in front of the mixer; this will make it easier to set the right level quickly when someone begins talking. As the event begins, watch your levels carefully; people often speak significantly louder when they are live. For more dynamic talkers, you may have to turn their average level down quite low in order to accommodate the occasional loud outburst.

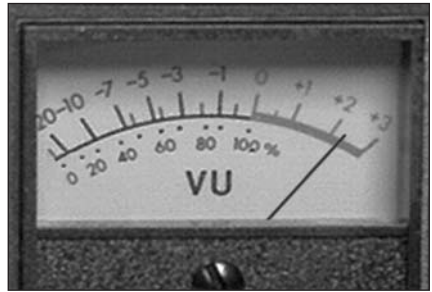

Average VU meter reading if level is set too high; may result in signal overload distortion

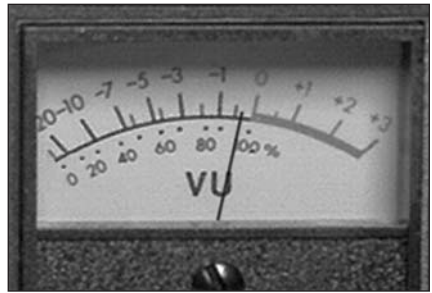

Average reading if level is properly set.



Average reading if level is set too low; may result in inadequate signal.

The mixer's tone oscillator and meter can also be used to establish consistent levels among several pieces of audio gear. For instance, during setup, the mixer's tone oscillator could be turned on, and the mixer's Master Output level control adjusted so that the mixer's output is set at a known level (as indicated on the level meter). The input of the recorder connected to the mixer would then be adjusted until its level meter indicated the same level as shown at the mixer. This means that acceptable readings on the mixer's meter during taping should also indicate acceptable levels at the recorder.

Different pieces of equipment may have dramatically different audio performance. You may find that you have to keep the mixer's output level very low to avoid overloading the input of a video recorder. If the recorder's audio input is designed in such a way that it overloads easily (without much headroom in other words), there is not much that you can do.

An important rule to remember when adjusting levels is keep input high, master low. In other words, it's better to have the input levels set at 7 or 8 and the master level set at 3 than to have the input levels at 3 and the master level at 8. Most of the internal noise or hiss produced by a mixer comes from the master output section, so the higher your master level control is set, the more noticeable this noise will be.

Monitor your audio! It is not uncommon for speaking or background noise levels to change significantly during a video shoot or other event, and if you're not listening, you won't find out until it's too late. Use a pair of lightweight headphones or a small earpiece to monitor — after all, how often do you tape an event without looking through your camera's



Example of a portable stereo mixer (Shure FP33 shown).

CONNECTING TO CAMCORDERS

Connecting a microphone with an XLR connector to a mixer input with an XLR connector is simple. Things can get more complicated when you must interconnect balanced and unbalanced devices, mono and stereo devices, or devices with different types of connectors. Connecting a microphone to a consumer or semi-professional camcorder equipped with a 3.5 mm miniplug microphone input is a good example.

Camcorders use a variety of microphone input connectors and wiring schemes. Unfortunately, there is no 'standard' to which camcorder manufacturers must adhere, and the specifications provided with the camcorder often say little or nothing about the microphone input. Most camcorder microphone inputs fall into one of three groups, however; the trick is knowing which group your camcorder is in.

The key questions are:

- Is the camcorder mono or stereo? If it is stereo, we assume that you wish to record the audio from your microphone onto both the left and right channels.
- If it is mono, does the microphone input jack supply DC voltage (sometimes labeled "Mic Power" or "+3 vdc") for the manufacturer's own accessory microphone? This DC voltage is not the same as the phantom power used for professional condenser microphones. Microphones or wireless receivers that do not require this power must be connected in such a way as to avoid contact with it. Professional condenser microphones requiring phantom power cannot be directly connected to a camcorder; a separate phantom power supply is required.
- If the camcorder is stereo, are there separate mono input jacks for the left and right channels, or a single stereo input jack that feeds both channels? If there are separate mono jacks, do they supply DC power.

Is A Transformer Necessary?

If the length of cable between the microphone and the camcorder will be 20 feet or less, all that is necessary is to use a cable with the appropriate connectors and wiring. If the cable will be longer than 20 feet, however, a transformer will be required at the end of the cable nearest the camcorder. The camcorder-side of the transformer is typically equipped with a very short cable and a 3.5mm mono or stereo connector.

The transformer provides two benefits:

- The transformer maintains a balanced connection between itself and the microphone, minimizing pickup of hum and electromagnetic interference and allowing for cable runs of up to 1,000 feet. (Longer cable runs require a mixer or preamplifier to boost the microphone signal up to Line level, about 1 volt.)

- The transformer can boost the signal level slightly, which may be useful when connecting a low-output microphone (or one used at a considerable distance from the sound source) to a camcorder whose microphone input is not very sensitive. The amount of boost (called “gain”) that the transformer provides depends on the ratio between its input and output impedances, as well as the ratio between the transformer’s output impedance and the camcorder’s input impedance. Typical transformers provide between 6 dB and 12 dB of gain.

Connecting A Mixer To A Camcorder

The output of a mixer can be connected to a camcorder’s mic input if the mixer has a mic level output. If the mixer only has a line level output, its level must be attenuated (decreased) by approximately 50 dB to prevent overloading of the camcorder’s microphone input circuitry. A device called an attenuator is used for this purpose. Some attenuators offer a choice of settings to provide varying amounts of attenuation. Some camcorders have a line level input in addition to the mic input.

If the cable run from the mixer to the camcorder is longer than 20 feet, a transformer is required, as discussed previously. Note: The mixer must have a mic level output, OR the transformer must be capable of handling a line level signal from the mixer without being overloaded (most cannot).

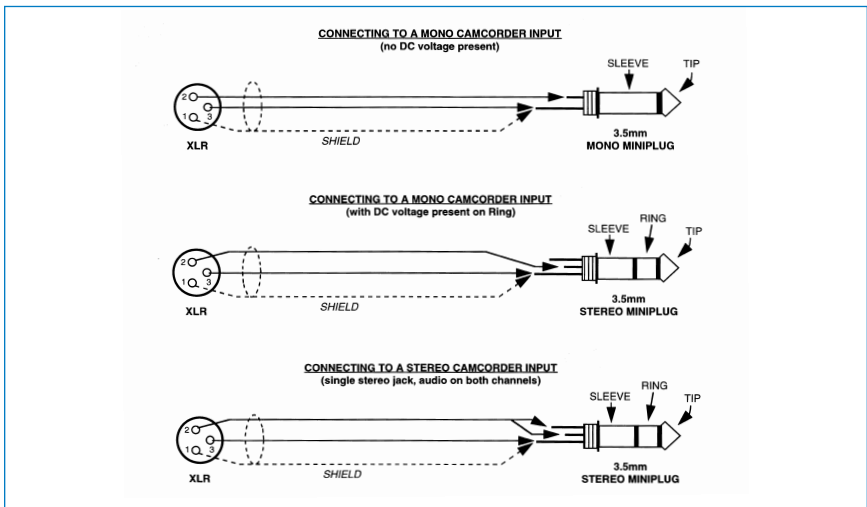

Connecting microphones to camcorders

VIDEO PRODUCTION

Dealing With Automatic Gain Control

Most consumer-grade camcorders and some industrial models have an Automatic Gain Control (AGC), which adjusts the audio level up or down as necessary. The AGC circuit is designed to compensate for the fact that the sound source is often far from the microphone on the camera. An external microphone is usually placed much closer to the source, however, and therefore a much higher signal level is fed into the camera's input. The Automatic Gain Control responds by rapidly reducing the audio level during the peaks of speech, and boosting the level up very high during pauses. The sound of the AGC's action is often described as “pumping”, “breathing”, or “whooshing”, and is usually undesirable. It is impossible to defeat or bypass the AGC on most camcorders.

The only other options are:

- Use the camcorder's line-level input, if it has one. On most camcorders, the line input is not affected by the AGC. But since a microphone signal is not strong enough to drive the line input directly, the mic must be connected to a mixer or microphone preamplifier that has a line level output. Using a mixer also allows for more precise adjustment and metering of signal levels, in addition to its basic function of combining the signals from multiple microphones into one feed.
- Keep the external mic signal level very low. This causes the AGC to relax and let the audio level rise to maximum. This tends to amplify the hiss of the camera's audio circuitry, but reduces the pumping action. The microphone's output signal can be reduced by moving it farther away from the source, or by using a device called an attenuator or pad, which decreases the signal level by a fixed amount. Some attenuators offer a choice of settings, such as -15 dB, -20 dB, and -25 dB.

HOW TO HANDLE SOME COMMON MIKING SITUATIONS

Following are some hints on choosing the right mics for some common audio/video applications. In most situations, there is no single “right way” to do it, but some ways may be better than others. In some cases, you may decide to sacrifice some sound quality in order to gain some other, more important benefit, such as accommodating your subject's refusal to wear a lavalier mic. There are some general ground rules that always apply, however:

1. Always place the microphone as close as is practical to the sound source. Every time the source-to-mic distance increases by a factor of two, the sound pressure level (SPL) reaching the mic decreases by a factor of four, making clear sound pickup progressively more difficult. This is called the inverse-square rule, and it applies whether the distance increases from 6 inches to 12 inches or from 6 feet to 12 feet. This means that the talker-to-mic distance must be cut in half to cause a significant improvement in sound quality.

2. Use the lowest number of microphones necessary for the situation. People sometimes have a tendency to “over-mike” a shot, using three or four microphones when one or two would be sufficient. Excess mics mean more background noise pickup, greater chance of feedback or “tin can” sound (both of which we’ll discuss in the Troubleshooting section), and more levels for the operator to keep track of. If additional mics don’t make things sound better, then they will probably make things sound worse.

Situation #1 — The Standup Shot: In this situation, a company officer or other speaker is either standing or sitting, speaking directly to the camera. If this takes place in a studio or quiet office, the best mic to use would be a lavalier, since the speaker’s hands would be free to gesture and we would eliminate the possibility of a handheld mic being positioned incorrectly or, worse yet, moved around. The unobtrusiveness of a lavalier mic also tends to put the talker more at ease, resulting in a more natural look and sound.

If the shot takes place outdoors or in a noisy factory, you will need a unidirectional mic to cut down the background noise. You could: 1) use a unidirectional lavalier mic, 2) have the speaker hold a handheld unidirectional mic (or put one on a stand in front of him), or 3) use a shotgun mic on a boom, positioned so that it does not appear in the video frame. This method also permits the talker to move around without getting tangled in a microphone cable.

Situation #2 — The Product Demo Shot: This time our speaker is demonstrating a product on a table. Before you decide what type of microphone to use, stop and think for a moment. Does this product make any sound at all when demonstrated? If so, how loud is it? Do you want the sound to be part of the demonstration? If the product makes little or no noise (like a personal computer, for instance), your best bet is probably to put a lavalier mic on the speaker’s clothing in a spot where it will not be disturbed by his movements.

If the product is a food processor, though, your only chance is to use the lavalier or a shotgun to pick up the first part of the demo (before the product is turned on), and then record the rest of the demo without any narration — just the sound of the unit working. Have the speaker do a voice-over without the machine on, which you can dub in later. Otherwise, you’ll have to use a shotgun mic positioned no more than a foot away from the speaker’s mouth and perpendicular to the food processor for minimal noise pickup.

If the product is very small and you have to pick up its sound (such as that of a digital watch alarm beeping), you will need to use a second mic positioned close to it, or else a shotgun a few inches away from it.

Situation #3 — The Panel Discussion Shot: Here, your assignment is to tape a panel discussion before a live audience. Let’s say that there are five people on the panel, and you also wish to pick up the questions and comments of the audience. You will be operating the camera yourself, so all the microphones will be on at all times to ensure that no comments are missed.

Audio Systems Guide for VIDEO PRODUCTION

How many mics you use on the panel depends largely on how closely together they are seated — you may be able to pair people up and use one microphone for each pair. Keep in mind that microphone positioning has a significant effect on sound quality, however. The rule for this situation is widely known among professional audio engineers, and you would do well to memorize it:

The 3-to-1 Rule — The distance between open microphones should be at least three times the distance from each microphone to the nearest talker.

For example, if you place a microphone one foot in front of each talker, the mics should be at least three feet apart from each other. Placing the mics closer together will result in a hollow, “tin can” sound, caused by the same sound reaching more than one microphone at slightly different times. If it’s convenient to have panel members positioned in pairs as mentioned above, you could separate each pair by a distance greater than three feet, allowing the microphones to be further away from each pair of talkers.

The best solution would be to turn off microphones that are not being addressed, which would keep the number of open microphones to a minimum and make the distance between mics less critical. This could be done either by a live operator or with a voice-activated mixer.

Picking up audience questions is a perennial problem for audio people, primarily because there is no really effective way to do it. For their comments to be intelligible, you have two choices: bring the audience to a microphone, or bring a microphone to the audience. In other words, you could place a mic on a stand somewhere in the room and ask people to move to that location if they have a comment. Or, you could assign a person (or persons) the task of walking around the room with a wireless mic and going to each person who has a question. You’re probably wondering about pointing a shotgun mic at each person to pick up their questions, but this doesn’t work very well. Shotgun mics are not very effective beyond 20 feet in a large crowded room, which means you will only be able to understand those people in the front row.

Situation #4 — The Conference Table Shot: Your main goal in this situation is to videotape a meeting of eight people seated around a rectangular conference table. You might think that the obvious solution would be to put a lavalier microphone on each person, but this arrangement would pick up tremendous amounts of room noise if all eight mics were left on at once. Having an operator bring each mic up and down as needed would probably prove unsatisfactory, since the flow of conversation might move too fast for the operator to keep up. Your best bet here is to use two omnidirectional surface mount microphones, located so that one mic is centered on each half of the table. Each person should be approximately the same distance from the nearest microphone. Otherwise, levels will be inconsistent and some speakers will not be picked up as well as others. If an audio person is available, he or she could also use a shotgun mic on a boom, although this method would make it difficult to pick up more than one person at a time. As we mentioned previously, a voice-activated mixer would be an excellent alternative.

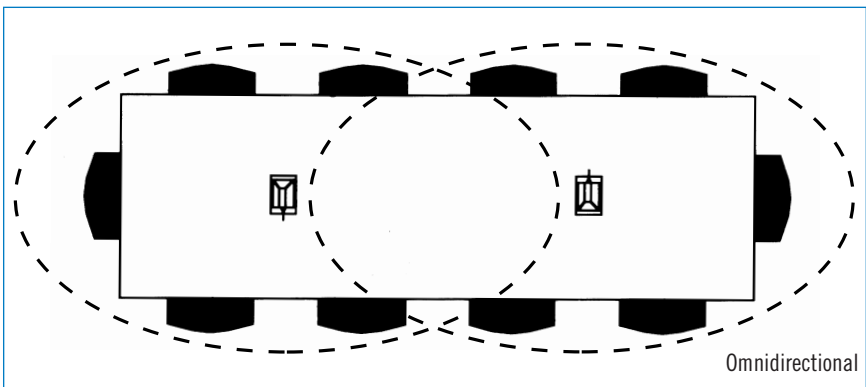
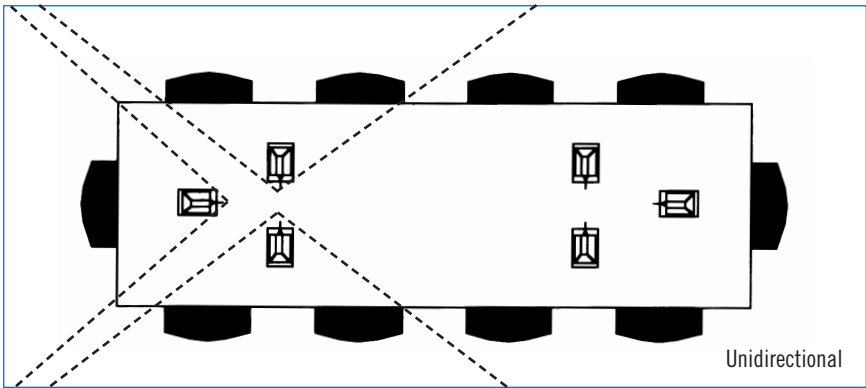

Two methods for miking a conference table

TROUBLESHOOTING

No matter how well you plan ahead, sooner or later you will probably run into an audio-related problem. To help you out in those situations, we've listed some of the more common problems encountered in doing audio-for-video, along with some possible solutions.

1. **Buzz, hum, crackle, and other noises** — These are almost always caused by an electrical problem somewhere in the system. A low, steady buzz or intermittent crackle usually indicates a loose ground wire, probably in or near a connector. A humming sound is usually picked up by unbalanced cables near light fixtures, dimmer switches, or power or loudspeaker cables. You can try moving the mic cable around a bit, but

Audio Systems Guide for VIDEO PRODUCTION

the only permanent solution is to use balanced microphone cables. If your microphone is the unbalanced, high-impedance type, you can save yourself some headaches by using an in-line transformer which converts the signal to the balanced, low-Z configuration. You can then plug the mic into a balanced mic input or use another transformer to convert the signal back to high-Z to match the equipment's input. It's important that the transformer is used as close to the microphone end of the cable as possible, so that the majority of its length is balanced. Placing the transformer at the mixer input will not make the mic cable more resistant to electrical noise.

2. *Distortion* — This “fuzziness” or general lack of clarity results when the input of some piece of equipment in your audio chain is being overloaded (a condition called clipping). Once the signal is distorted, there is absolutely no way to remove the distortion with another device further down the audio chain. If the signal level coming from the microphone is too high for the mixer and sounds distorted, for example, you must turn down that channel's input level control on the mixer. Adjusting the input control on the videotape recorder will not help. If the range of adjustment is not wide enough, you can use an attenuator (also called a pad), which reduces the level of the signal by a specified amount without altering its sound. The amount of attenuation is measured in decibels, or “dB” for short. A 10 dB or 20 dB attenuator is frequently all that is required to make a signal easier for the mixer to deal with; a 50 dB attenuator will bring a line-level signal all the way down to mic level.



Examples of transformers

3. “*Tin can*” sound — This usually results when the microphone is located too far from the talker. The more reverberant the room is, the closer the microphone must be in order to obtain good sound quality. “Tin can” sound can also be caused by phase cancellation, which occurs when the same sound waves reach more than one microphone at slightly different times. When the signals are combined at the mixer, the time delay between them causes unpredictable changes to the signal, resulting in a strange sound. The easiest way to avoid this problem is to observe the 3-to-1 rule.

- 4. “Popping” and wind noise** — Popping is caused by an explosive sound wave striking the microphone diaphragm, such as that which occurs when a talker says words beginning with the letters “p” or “t”. To lessen the likelihood of this phenomenon occurring, you should: 1) keep the microphone at least 6 inches away from the talker’s mouth, tilted toward the user at about 45 degrees from vertical, and 2) use a foam windscreen if the microphone’s built-in pop filter is insufficient or if a very close source-to-mic distance is required. Wind noise is frequently a problem outdoors, especially with condenser microphones. The only solution is to use a foam windscreen, and in extreme conditions, a “zeppelin” or “blimp” type windscreen such as those used on shotgun microphones.
- 5. Vibration noise** — This is usually heard in the form of low “thumping” when someone taps or bangs on the stand or lectern on which the microphone is mounted. It can be reduced (although not always eliminated) through the use of a shock mount. This is a special mounting bracket for the microphone which uses rubber or elastic to isolate the microphone body from mechanical noise. An external shock mount may be essential if the microphone has little or no internal shock mount of its own.
- 6. Feedback** — If you are using microphones to feed a loudspeaker system in the same room, you may occasionally encounter feedback (a loud howl or squeal when microphones are moved too close to the loudspeakers.) Feedback is usually caused by a combination of several factors such as speaker volume, placement of mics and loudspeakers, and room acoustics. The easiest way to improve the situation is to adjust those factors over which you have some control — microphone pickup pattern, mic placement, loudspeaker location, and loudspeaker volume - so that they don’t interfere with each other. For instance, in any given feedback situation, you could: 1) move the microphone farther away from the loudspeakers, 2) move the loudspeakers farther away from the microphone, 3) switch to a microphone with a more directional pickup pattern, or 4) turn down the overall volume of the sound system. There is no known device which will eliminate feedback; proper use of microphones and loudspeakers is usually the only solution.

A FEW FINAL WORDS

The most important thing you can do to improve the audio quality of your productions is plan ahead. When you walk into a room to begin setting up your equipment, take a good look around you. Identify things that might cause a problem with your audio (such as air conditioning ducts) as well as those which you might be able to use to your advantage (such as sound absorbent carpeting in one section of the room). Think about what or who you will be miking, and what your options are in getting the sound on tape. Don't be afraid to experiment with different mic placements, but don't gamble an important project on a method you've never tried before. When you monitor your audio, listen carefully for anything that sounds unnatural. As the saying goes, "if you notice the sound, there's something wrong with it".

The charts on pages 34-35 of this guide identify some Shure microphones, mixers, and accessories frequently used in audio/video applications. Further information on Shure products is available to audio/video production professionals at no charge. Write to:

**Shure Incorporated
Customer Service
5800 West Touhy Avenue
Niles, IL 60714-4608
Phone: 1-800-25-SHURE**

MORE RESOURCES

Finally, we've included a reading list for those of you who would like to learn more about the technical aspects of audio. The resources below are comprehensive, yet for the most part do not require that the reader have an extensive technical background.

Eargle, John

[The Microphone Book](#)

Published by Focal Press

Bartlett, Bruce

[Practical Recording Techniques](#)

Published by Focal Press

Davis, Gary and Jones, Ralph

[Sound Reinforcement Handbook](#)

Published by Hal Leonard

Miles-Huber, David and Williams, Philip

[Professional Microphone Techniques](#)

Published by Artistpro

Note: *A wide variety of books about audio, including the ones listed above, are available online from AMAZON.com.*

MIXERS

MODEL	INPUTS	OUTPUTS	POWER REQUIREMENTS	PHANTOM POWER	SPECIAL FEATURES
FP33	3 XLR mic/line	2 XLR mic/line (left-right)	2 x 9-volt batteries	Yes; 48-volt also 12-volt A-B	Stereo; very low noise
FP410	4 XLR mic/line	2 XLR mic/line	AC or 2 x 9-volt batteries	Yes	Voice-activated automatic mixer
SCM262	2 XLR mic; 3 stereo RCA	2 1/4" mic/line; 1 stereo RCA	AC only	Yes; 12 volts	Stereo; ducking circuit for voiceovers
SCM268	4 XLR mic; 5 RCA	XLR mic/line; RCA	AC only	Yes; 12 volts	LED peak output meter

PROBLEM SOLVERS

MODEL	DESCRIPTION
A15AS	Switchable Microphone Attenuator. Provides 15, 20, or 25 dB attenuation.
A15LA	Line Input Adapter. Provides 50 dB attenuation; permits connection of balanced line-level signal to balanced mic-level input.
A15TG	Tone Generator. Produces continuous 700 Hz signal for setting up and trouble shooting equipment; battery operated.
A95U	Low-impedance to high-impedance matching transformer. Male XLR connector on low-Z end; 1/4" phone jack and phone plug included for high-Z end.
A95UF	Same as A95U, but female XLR connector on low-Z end.
A96F	Low-impedance to medium-impedance transformer for connecting professional microphones to camcorders. Female XLR connector on microphone end; two-foot cable with 3.5mm miniplug on camcorder end. Internal filter to block DC bias voltage.

MICROPHONES

MODEL	PHYSICAL DESIGN	PICKUP PATTERN	ELEMENT TYPE	IMPEDANCE	SPECIAL FEATURES
SM58	Handheld	Cardioid	Dynamic	Low	Crisp, clear sound, very reliable
SM63L, SM63LB (black)	Handheld	Omni	Dynamic	Low	Great interview mic; heavy-duty shock mount
MX183	Lavalier	Omni	Condenser	Low	Small size; bright sound
MX184	Lavalier	Supercardioid	Condenser	Low	Directional pattern rejects noise
MX185	Lavalier	Cardioid	Condenser	Low	Directional pattern rejects noise
SM89	Shotgun	Line/Gradient	Condenser	Low	Highly directional
MX391/O	Surface mount	Omni	Condenser	Low	Low profile design
MX391/C	Surface mount	Cardioid	Condenser	Low	Directional low profile
VP64A, VP64AL (long)	Handheld	Omni	Dynamic	Low	Neodymium magnet ergonomic design
VP88	Handheld/ Camera mount	Stereo Mid Side	Condenser	Low	True MS stereo, mono compatible switch selectable stereo spread
WL93	Wireless lavalier	Omni	Condenser	Low	Micro-miniature, uniform frequency response
WL50	Wireless lavalier	Omni	Condenser	Low	Subminiature; black, tan, white
WL51	Wireless lavalier	Cardioid	Condenser	Low	Subminiature; black, tan, white
WCB6	Wireless lavalier	Omni	Condenser	Low	Subminiature; black, tan

ABOUT THE AUTHOR

Chris Lyons

Chris Lyons is **Manager, Technical and Educational Communications**, with Shure Incorporated. With more than 21 years of experience in training, technical support, and product management at Shure, he has presented training sessions for retail salespeople, created online training content, and supervised the deployment of third-party in-store product demonstrators, both in the U.S. and abroad. He has written numerous articles and technical papers, including *Introduction to Wireless Systems* and *Audio For Distance Learning*.

Additional Shure Publications Available:

Printed and electronic versions of the following guides are available free of charge. To obtain your complimentary copies, call one of the phone numbers listed below or visit www.shure.com.

- Selection and Operation of Personal Monitor Systems
- Selection and Operation of Wireless Microphone Systems
- Microphone Techniques for Sound Reinforcement
- Microphone Techniques for Studio Recording

Our Dedication to Quality Products

Shure offers a complete line of microphones and wireless microphone systems for everyone from first-time users to professionals in the music industry—for nearly every possible application.

For over eight decades, the Shure name has been synonymous with quality audio. All Shure products are designed to provide consistent, high-quality performance under the most extreme real-life operating conditions.



SHURE[®]
LEGENDARY
PERFORMANCE[™]

United States, Canada, Latin America, Caribbean:

Shure Incorporated, 5800 West Touhy Ave, Niles, IL 60714-4608, USA
Phone: 847-600-2000 US Fax: 847-600-1212 Int'l Fax: 847-600-6446

Europe, Middle East, Africa:

Shure Europe GmbH, Phone: 49-7131-72140 Fax: 49-7131-721414

Asia, Pacific:

Shure Asia Limited, Phone: 852-2893-4290 Fax: 852-2893-4055